

Versione ad **ASSE NUDO**

BARESHAF construction

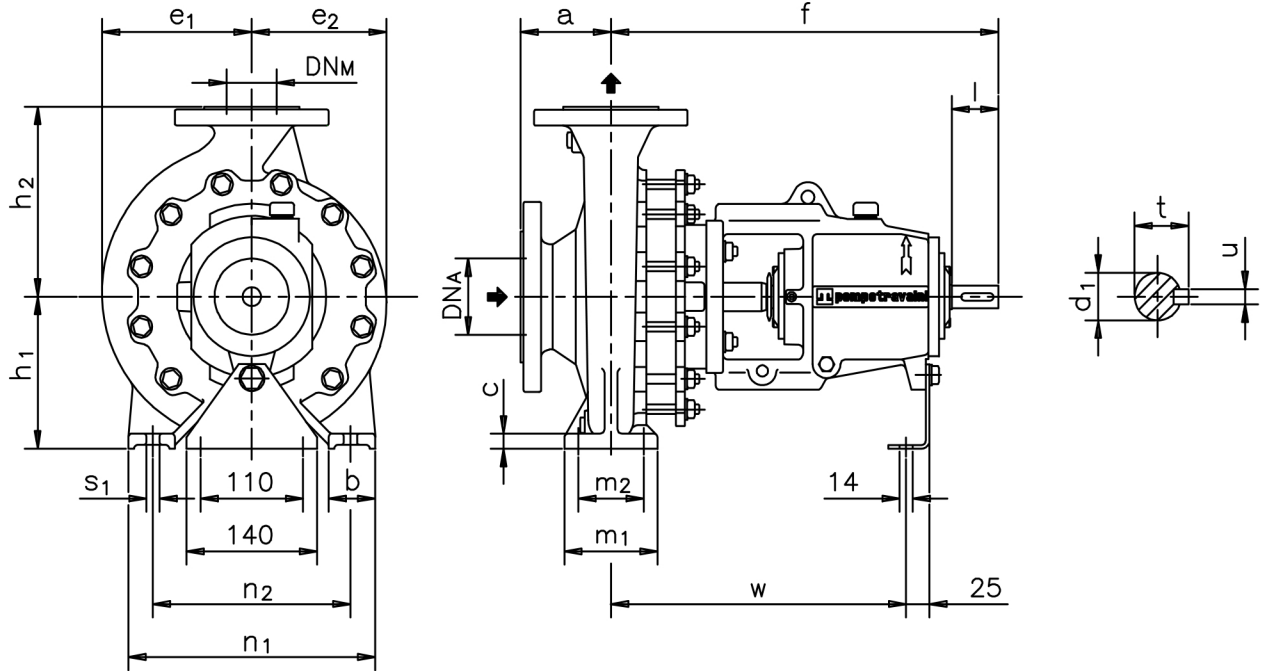

Pompa tipo Pump type	Versione ad ASSE NUDO BARESHAF construction																			Peso Weight	
	DN _A	DN _M	a	f	h ₁	h ₂	b	c	m ₁	m ₂	n ₁	n ₂	s ₁	w	d ₁	l	t	u	e ₁		e ₂
32-125	50	32	80	405	112	140	50	15	100	70	190	140	14	305	24	50	27	8	105	91	36
32-160	50	32	80	411	132	160	50	16	100	70	240	190	14	311	24	50	27	8	125	110	42
32-200	50	32	80	411	160	180	50	16	100	70	240	190	14	311	24	50	27	8	140	130	46
40-125	65	40	80	405	112	140	50	15	100	70	210	160	14	305	24	50	27	8	115	100	38
40-160	65	40	80	411	132	160	50	16	100	70	240	190	14	311	24	50	27	8	130	115	42
40-200	65	40	100	411	160	180	50	16	100	70	265	212	14	311	24	50	27	8	146	135	48
40-250	65	40	100	533	180	225	65	18	125	95	320	250	14	403	32	80	35	10	176	163	85
50-125	80	50	100	405	132	160	50	16	100	70	240	190	14	305	24	50	27	8	130	110	42
50-160	80	50	100	411	160	180	50	16	100	70	265	212	14	311	24	50	27	8	147	125	47
50-200	80	50	100	411	160	200	50	16	100	70	265	212	14	311	24	50	27	8	161	146	49
50-250	80	50	125	533	180	225	65	18	125	95	320	250	14	403	32	80	35	10	183	169	90
65-160	100	65	100	526	160	200	65	16	125	95	280	212	14	396	32	80	35	10	160	130	75
65-200	100	65	100	526	180	225	65	18	125	95	320	250	14	396	32	80	35	10	174	152	82
65-250	100	65	125	539	200	250	80	20	160	120	360	280	18	409	32	80	35	10	195	175	90
80-160	125	80	125	526	180	225	65	16	125	95	320	250	14	396	32	80	35	10	186	142	80
80-200	125	80	125	526	180	250	65	18	125	95	345	280	14	396	32	80	35	10	188	158	95
80-250	125	80	125	539	225	280	80	20	160	120	400	315	18	409	32	80	35	10	225	185	112
100-200	125	100	125	526	200	280	80	20	160	120	360	280	18	396	32	80	35	10	211	170	112

Disegno schematico. Dimensioni in mm con tolleranze secondo EN 735-1995. Pesi indicativi in Kg, riferiti a pompe in esecuzione "GS" ghisa sferoidale escluso motore, non impegnativi.
 Schematic drawing. Dimensions in mm with tolerances to EN 735-1995 standards. Weights in Kgs, referred to pump in ductile iron "GS" construction without motor, not binding.